

6" PRV STATION PLAN
N.T.S.

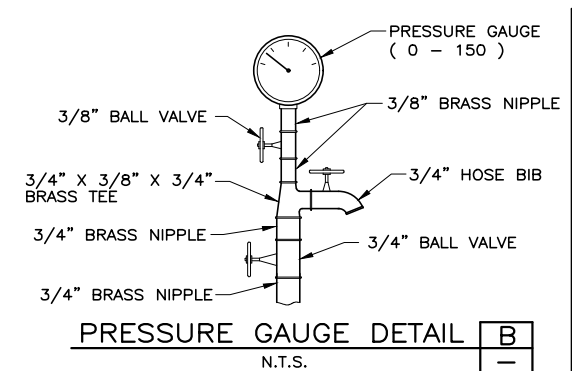

PRESSURE GAUGE DETAIL
N.T.S.

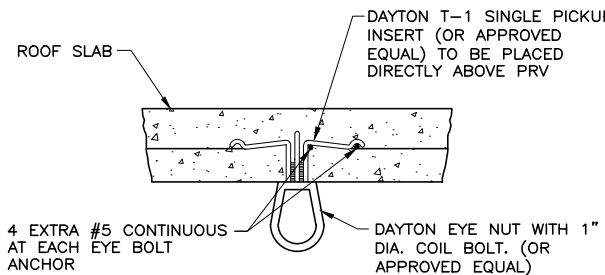

EYE BOLT DETAIL
N.T.S.

PRESSURE REDUCING STATION VALVE AND FITTING SCHEDULE			
NO.	DESCRIPTION	SIZE	JOINT
1.	WALL PIPE W/THRUST RING	4" X 2'-0"	FLG
2.	TEE W/ 3/4" TAP	4" X 3"	FLG
3.	CROSS W/ 3/4" TAP	4" X 3"	FLG
4.	GATE VALVE (SEE TABLE NOTES)	4"	FLG
5.	SPOOL PIECE	4" X 9"	FLG
6.	NIPPLE	4"	FL X PE
7.	FLANGE COUPLING ADAPTER	4"	FL X PE
8.	PRESSURE REDUCING VALVE (CLA-VAL 90-01)	4"	FLG
9.	GATE VALVE (MUELLER RESILIENT SEAT)	3"	FLG
10.	PRESSURE RELIEF VALVE (CLA-VAL 50-01)	3"	FLG
11.	FLANGE COUPLING ADAPTER	3"	FLG X PE
12.	BRASS PIPE	3"	THD
13.	REDUCING FLANGE	7 1/2" X 2"	FLG X THD
14.	BRASS PIPE	2"	THD
15.	BRASS 90° ELBOW	2"	THD
16.	BRASS UNION	2"	THD
17.	PRESSURE REDUCING VALVE (CLA-VAL 90-01)	2"	THD
18.	PIPE SUPPORT (GRINNELL MODEL NO. 264)	-	-
19.	REDUCER WITH MEGALUG RESTRAINT ON INFLOW SIDE	8" X 6"	MJ

TABLE UNLESS OTHERWISE SPECIFIED, ALL PIPE AND FITTINGS ARE DIP CLASS 53.
 NOTES: ALL FLANGES ARE ANSI CLASS 125.
 PROVIDE MEGALUG RESTRAINT ON ALL MJ FITTINGS.
 PROVIDE BRONZE OR STAINLESS STEEL BOLTS FOR ALL CONNECTIONS WITHIN VAULT.
 MUELLER RESILIENT SEAT, CLOW RESILIENT WEDGE OR EAST JORDAN GATE VALVE.

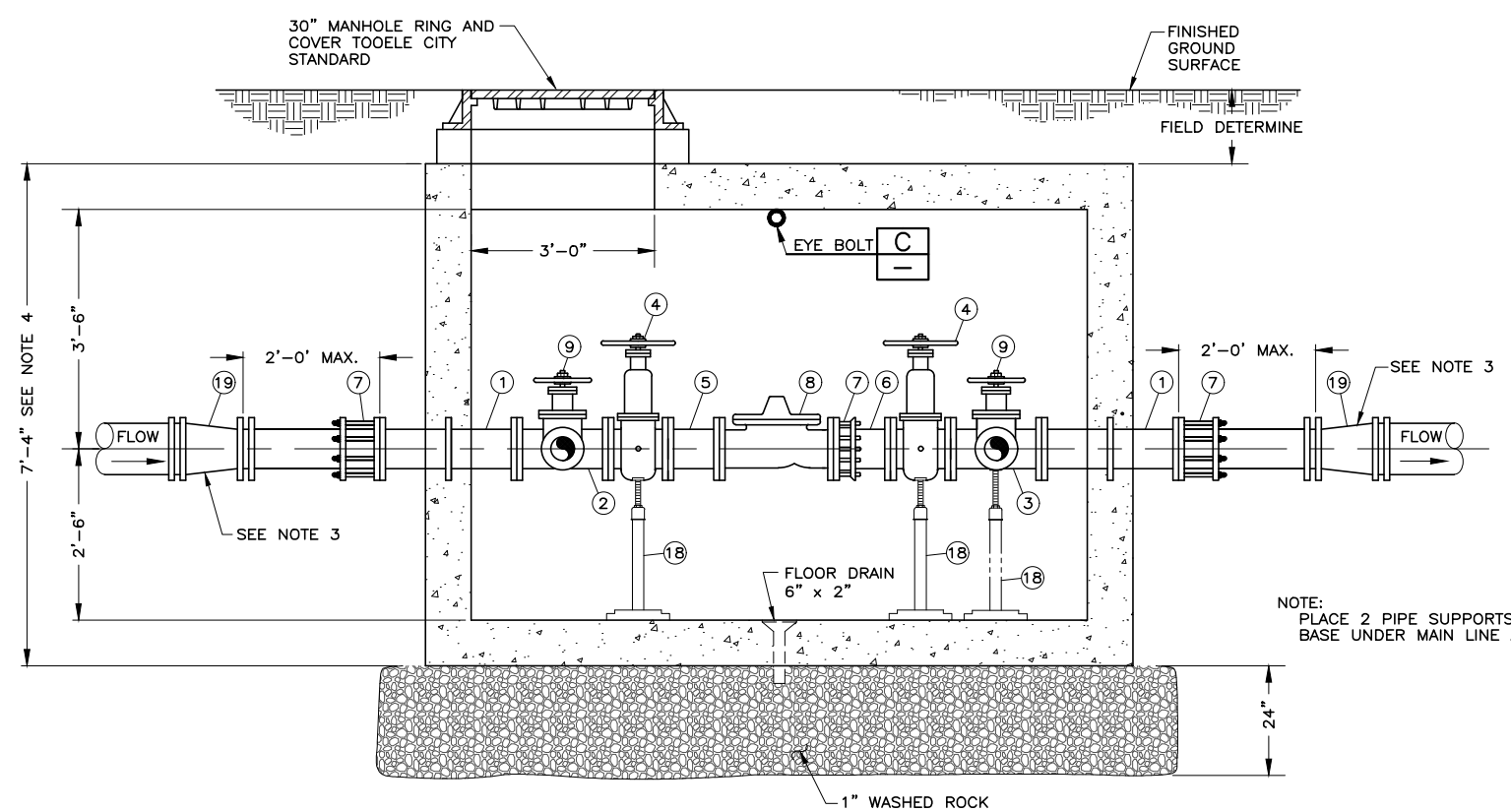

SECTION 1
N.T.S.

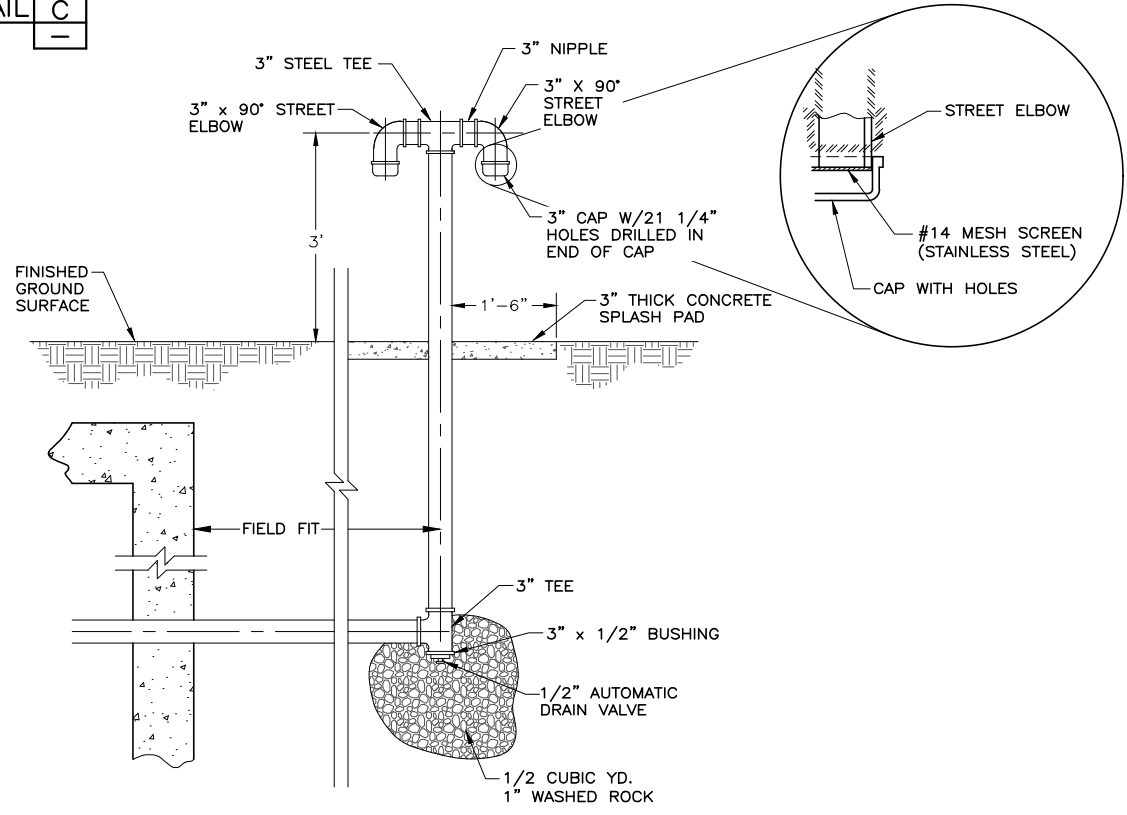

PRESSURE RELIEF PIPE
N.T.S.

- NOTES:
1. ALL PIPE ABOVE GROUND TO BE GALVANIZED STEEL.
 2. LOCATION OF PRESSURE RELIEF PIPE TO BE FIELD FIT BY ENGINEER.
 3. PROVIDE THRUST WALL DESIGN FOR 150 PSI MIN. OPERATING PRESSURE. PROVIDE REDUCER OR SOLID SLEEVE, BOTH WITH MEGALUG RESTRAINT, AS REQUIRED TO MATCH EXISTING PIPE CONDITIONS.
 4. VAULT DIMENSIONS SHOWN ARE FOR INFORMATIONAL PURPOSES ONLY. H-20 MIN. LOADING REQUIRED. PROVIDE SHOP DRAWINGS FOR ENGINEERS APPROVAL PRIOR TO CONSTRUCTION.

4" PRESSURE REDUCING VALVE WITH 2" BYPASS

